



Techni
ENGINEERING SOLUTIONS

MERCEDES NEW ATEGO
967, 970 - 976

CODE / CODICE: 0500.7192

**COMPRESSOR / COMPRESSEUR / KOMPRES-
SOR / COMPRESSORE / COMPRESOR :
SELTEC SP13 / 15 / 16
QUE TM13 / 15 / 16**

**FITTING INSTRUCTIONS
EINBAUANLEITUNGEN
INSTRUCTIONS POUR LE MONTAGE
ISTRUZIONI DI MONTAGGIO
INSTRUCCIONES DE MONTAJE**

Contents

ENGLISH	4
Parts View.....	4
Parts List	5
Compressor Configurations	6
Standard Fastener Torque Values	6
Kit Details	7
Vehicle Details	7
Forward	7
Pre Installation.....	8
Installation	8
Mount Bracket Installation	11
Compressor Installation.....	12
Drive Belt Installation	13
Finish	13

PARTS VIEW / VUE ÉCLATÉE / TEILEANSICHT / VISTA PARTA / IMÁGENES DE LAS PIEZAS

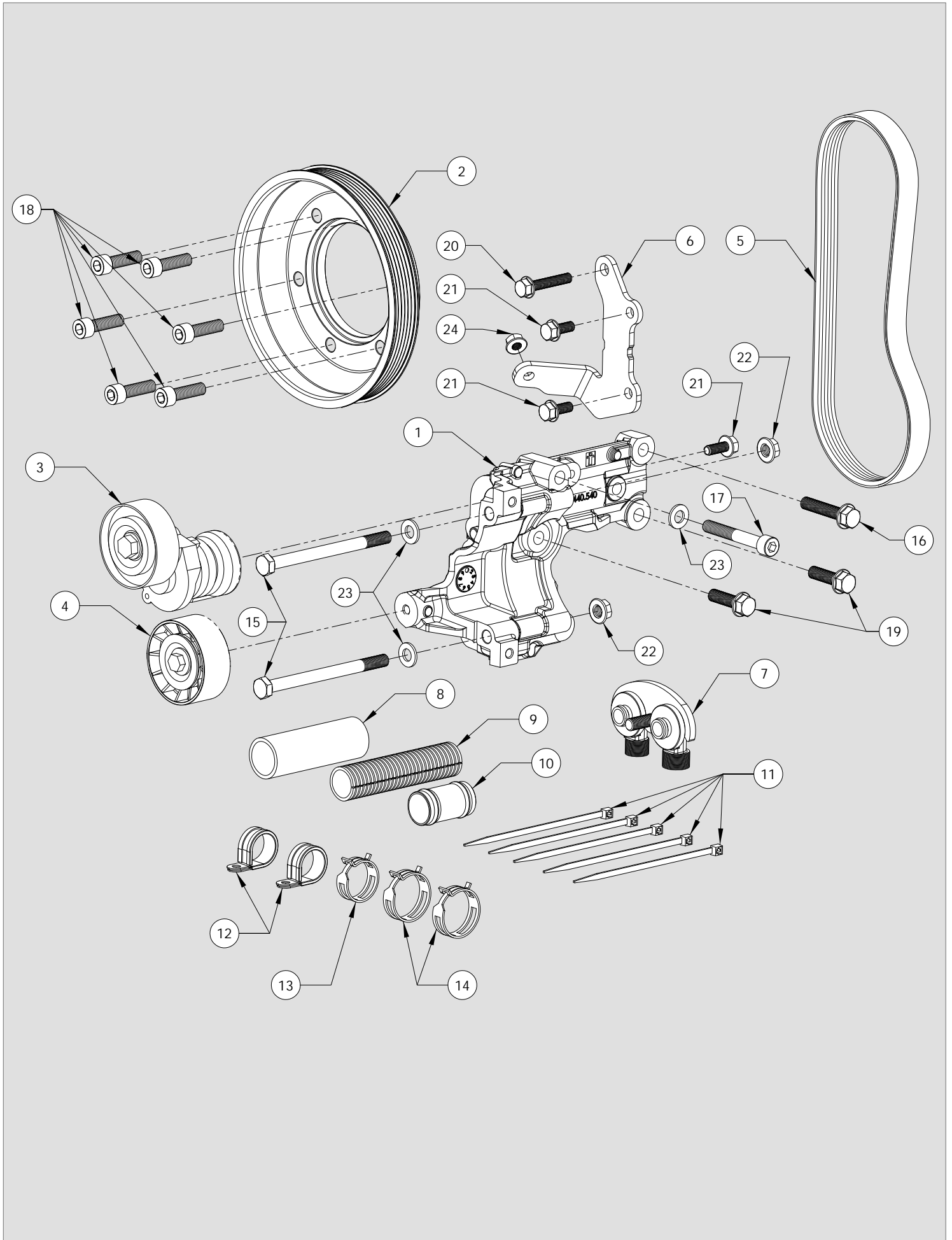

PARTS LIST / NOMENCLATURE / TEILELISTE / ELENCO DELLE PARTI / LISTA DE PIEZAS

ITEM	CODE / CODICE / KODE / CODIGO	DESCRIPTION / DESCRIZIONE / BESCHREIBUNG / DESCRIPCION	QTY.	COMMENTS
1	0441.5401	Compressor Mount Bracket Assembly	1	
2	1701.5311	Crankshaft Pulley	1	
3	1705.5031	Automatic Tensioner	1	
4	1700.0331	Idle Pulley Assembly	1	
5	0820.5781	Belt - Poly Groove 6Pk 1173	1	
6	3020.5931	Atego Support Plate	1	
7	0425.0521	Manifold Assembly Adjustable 3/4 X 7/8	1	
8	1420.0002	Oil Fill Hose	1	
9	1430.0092	Nylon Split Tube	1	
10	1494.0021	Hose Adapter	1	
11	2763.0051	Cable Tie 4.8 X 370 - Black	5	
12	2771.1041	P Clip 25Mm	2	
13	1537.1021	Dynamic Hose Clip - 32Mm	1	
14	1537.1031	Dynamic Hose Clip - 38Mm	2	
15	2705.0531	Hexagon Head Bolt - M10 X 130 : 10.9	2	
16	2705.0341	Hex Flange Bolt Durlok - M10 X 50 : 1.50 - 12.9	1	
17	2705.5111	Hexagonal Socket Head Cap Screw M10 X 70 : 1.5- 12.9	1	
18	2705.5261	Hex Socket Head Cap Screw M10 X 35 : 1.50 - 10.9	6	
19	2705.0241	Hex Flange Bolt Durlok - M10 X 35 : 1.50 - 12.9	2	
20	2704.0161	Hex Flange Bolt Durlok - M8 X 45 : 1.25 - 12.9	1	
21	2704.0511	Hex Flange Bolt - M8 X 20 : 1.25 - 10.9	3	
22	2735.0071	Durlok Hexagon Flange Nut - M10 : 1.50	2	
23	2809.0011	Washer M10 Flat Din 125 - A 10.5	3	
24	2734.0021	Durlok Hexagon Flange Nut - M8 : 1.25	1	

**COMPATIBLE COMPRESSORS / COMPRESSEURS RECOMMANDÉS / EMPFOHLENE KOMPRESSOREN
RACCOMANDATO COMPRESSORI / RECOMENDADAS COMPRESORES**

SELTEC	TM-13 HS	TM15-HS	TM16-HS
Comp No	0381.0392	0381.0062	0381.0772
Valeo No.	435-54123	435-55123	435-56123
Mounting	Ear	Ear	Ear
Rotor	8PV	8PV	8PV
GL	46.55mm	46.55mm	46.55mm
Armature	3E	3E	3E
Diameter	123	123	123
Voltage	24	24	24
Orientation	H	H	H
Fitting	3/4 x 7/8	3/4 x 7/8	3/4 x 7/8
Manifold	Bolt	Bolt	Bolt

QUE	QP13-HD	QP15-HD	QP16-HD
Comp No	0391.0392	0391.0062	0391.0772
Que No.	QP13-1460	QP15-1526	QP16-1352
Mounting	Ear	Ear	Ear
Rotor	8PV	8PV	8PV
GL	46.55mm	46.55mm	46.55mm
Armature	3E	3E	3E
Diameter	123	123	123
Voltage	24	24	24
Orientation	H	H	H
Fitting	3/4 x 7/8	3/4 x 7/8	3/4 x 7/8
Manifold	Bolt	Bolt	Bolt

SANDEN	-	-	-
Comp No	-	-	-
Sanden No.	-	-	-
Mounting	-	-	-
Rotor	-	-	-
GL	-	-	-
Armature	-	-	-
Diameter	-	-	-
Voltage	-	-	-
Orientation	-	-	-
Fitting	-	-	-

NOTES

STANDARD FASTENER TORQUE VALUES

In the absence of specific torque values detailed in this fitting instruction manual, the following chart can be used as a guide to the maximum safe torque for specific size and grade of fastener.

COUPLES DE SERRAGE DES FIXATIONS STANDARDS

Si des chiffres de serrage au couple particuliers ne sont pas indiqués dans cette notice de montage, se référer au tableau suivant qui servira de guide pour le couple de sécurité maximum correspondant à une taille et un grade spécifiques de fixation.

ANZIEHMOMENTE FÜR STANDARDBEFESTIGUNGSMITTEL





Falls in dieser Einbauanleitung keine speziellen Anziehmomente angegeben sind, kann die folgende Tabelle als Richtlinie für das maximale sichere Anziehmoment für eine spezifische Größe oder Qualität von Befestigungsmitteln dienen.

VALORI STANDARD DI SERRAGGIO PER DISPOSITIVI DI FISSAGGIO

In assenza di valori specifici di coppia nel presente manuale di istruzioni, si può utilizzare la seguente tabella come guida per conoscere la coppia massima sicura in base a dimensioni e grado del dispositivo di fissaggio.

VALORES ESTÁNDAR DE LOS PARES DE APRIETE Y FIJACIÓN

En ausencia de valores para los pares de apriete específicos detallados en este manual de instrucciones de montaje, se puede utilizar la siguiente tabla como guía para consultar el máximo par de torsión seguro para un tamaño concreto y su grado de fijación.

STRENGTH								
	Max Torque		Max Torque		Max Torque		Max Torque	
Dia / Pitch	lb.ft	Nm	lb.ft	Nm	lb.ft	Nm	lb.ft	Nm
M5 x 0.80	2	3	4.5	6	6.5	9	7.5	10
M6 x 1.00	4	5.5	7.5	10	11	15	13	18
M8 x 1.25	10	13	18	25	26	35	33	45
M10 x 1.25	20	27	39	53	57	78	66	90
M10 x 1.50	18	25	37	50	55	73	63	86
M12 x 1.75	33	45	63	85	97	130	111	150
M14 x 2.00	55	75	103	140	151	205	177	240
M16 x 2.00	85	115	159	215	232	315	273	370

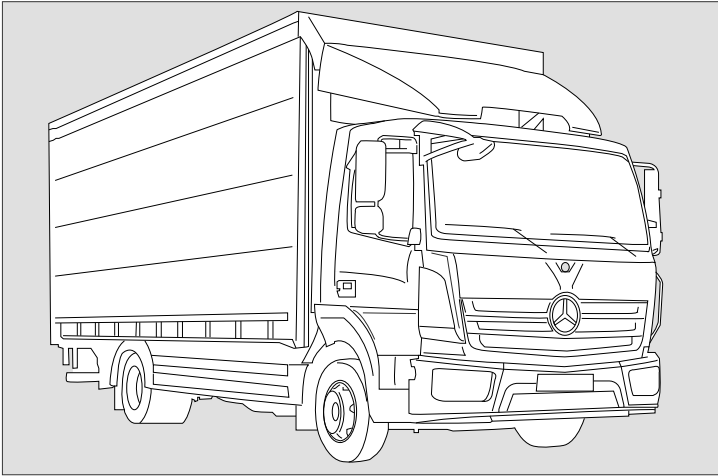

VEHICLE DETAILS

Manufacturer	Mercedes
Make	New Atego Euro VI
Model	967, 970 - 976
Engine	5.1 L 4 Cyl / OM934 E6
Engine Details	115 / 130 / 155 / 170 Kw 156 / 177 / 211 / 231 PS
Year	01.14>
Chassis Nos.	N/A
LHD	YES
RHD	YES
PAS	YES
A/C	YES / NO
Voltage	24v

KIT DETAILS

Kit Part Number	0500.7192
Description	Speed Reduction Kit
Compressor RPM	:3450 @ Max engine power output
Fitting Time	90 Minutes
Suction Fitting	90°
Discharge Fitting	90°
Belt Type	6PK 1173
Belt Part Number	0820.5781
Note:	Compatible with or without option N7C Not compatible with N7E, N7H or N7V options

FOREWORD

The purpose of this manual is to facilitate the installation of a direct drive compressor. The information given is merely instructive, should any complications arise contact the Technical department. The manufacturer's warranty does not cover any problems caused by defective installation or alterations made unless authorised. The manufacturer shall not be responsible for any injury, damage or loss caused directly or indirectly as a result of using this manual or the information contained within it.

1 SAFETY MEASURES:

Before fitting the Compressor adapter drive kit, ensure the following for damage:

- a Inner and outer trim and body work
- b Engine idle pace
- c Check all the vehicle functions

Check list:

- a Ensure that the right kit has been selected
- b Before installing, check that all the correct pieces are present; also ensure that there are no missing or broken pieces
- c When fitting, make sure the vehicle is properly protected against damage.

Installation apparatus

- a Calibrated torque wrench
- b Hand service tools
- c Protective covers and shields

2 PRECAUTIONS

- a Detach the battery negative lead.
- b Torque all bolts where stated using a calibrated torque wrench.
- c Take extreme care with moving parts.
- d Remove the vehicle's ignition key and keep it with you.
- e Wear safeguards and make sure that liquid refrigerant never touches your skin

Caution: Measures must be followed accurately to steer clear of the possibility of damage to individuals

Warning: This calls awareness to actions which must be pursued to avoid damage to the components.

NB: This calls awareness to make the job easier or gives useful information.

Note: Before proceeding please read the installation precautions. The letters on drawings relate to text, numbers circled relate to the parts list in this manual.

INSTALLATION

1. Disconnect the Battery
2. Remove the engine under tray
3. Disconnect the fan plug (A), Remove and retain p-clip (B) – Fig 1
4. Remove wiring plug (C) from bracket (D)
5. Remove and discard p-clip (E)
6. Remove and discard bracket (D) and 2x securing bolts – Fig 2
7. Remove and retain the 2x bolts (F) securing the fan loom to the fan hub (G)
8. Remove and retain the 6x securing bolts (H) securing the fan to the fan hub (G) – Fig 3
9. Remove and discard the 6x securing bolts (J) securing the fan hub (G) to the crankshaft pulley. Carefully place the fan hub in the radiator cowl – Fig 4

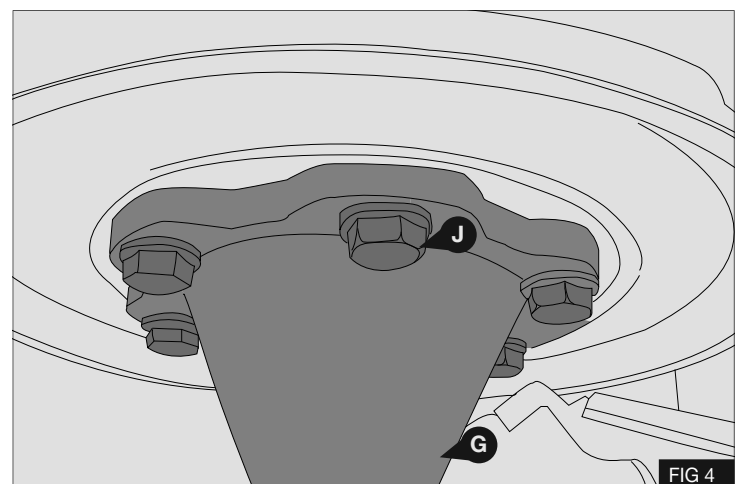
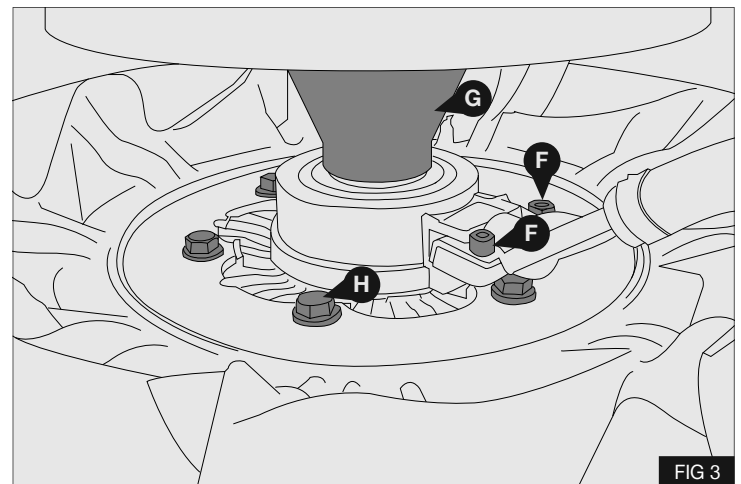
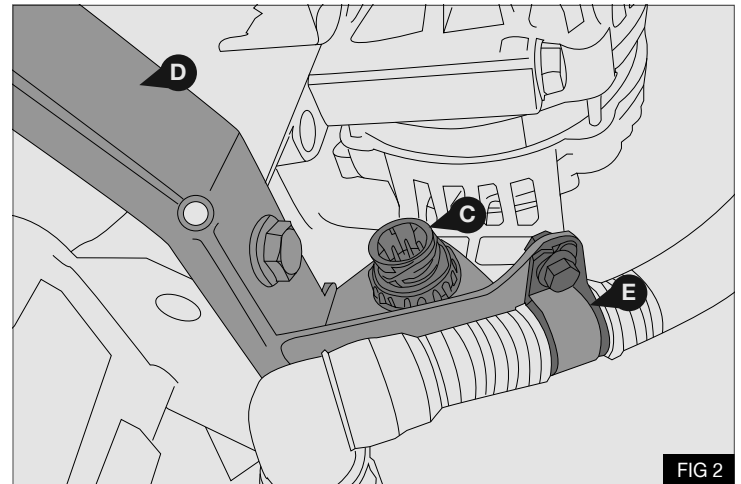
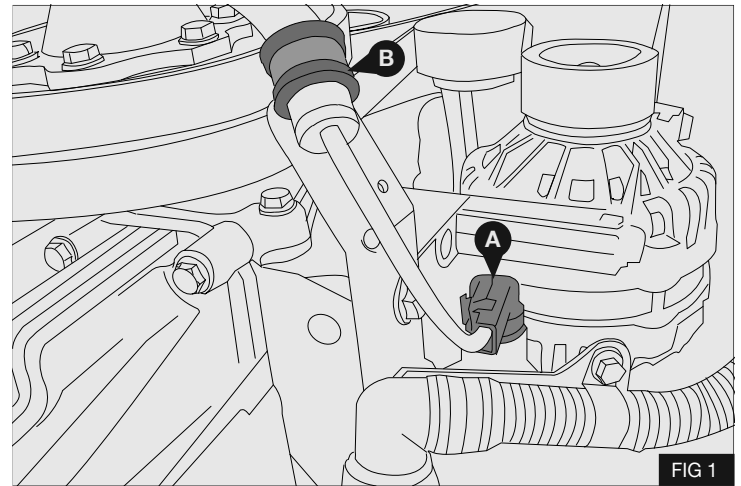

10. Secure the fan hub (G) and the supplied pulley (2) to the original crank pulley (K) using the supplied bolts (18) as shown opposite. Place the supplied belt (5) over the crank pulley (2). Torque bolts (18) to 50Nm / 36.8lb ft
- Fig 5

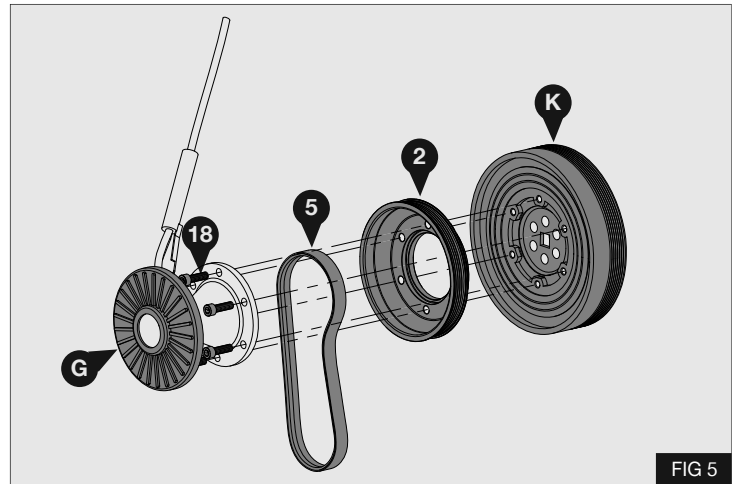

11. Refit the 6x securing bolts (H) securing the fan to the fan hub (G). Refit the bolts (F) securing the fan loom to the fan hub (G) - Fig 6

Torque bolts (H) to 25Nm / 18.4lb ft

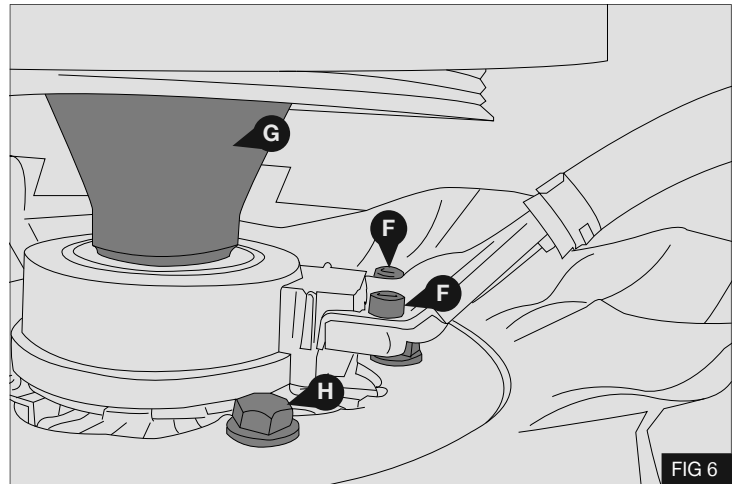

12. Locate the remote oil fill hose connection to the vehicle cab. Remove cable tie (K) - Fig 7

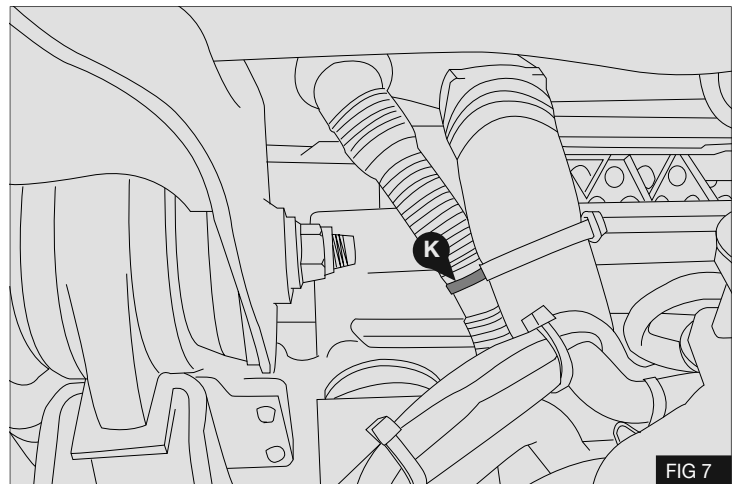

13. Disconnect the oil fill hose from the cab by squeezing at points (L). Twist and remove the hose fitting (M) from pipe (N) - Fig 8

14. Place the aluminium hose adapter (10) inside the oil pipe (N), secure using hose clip (13).

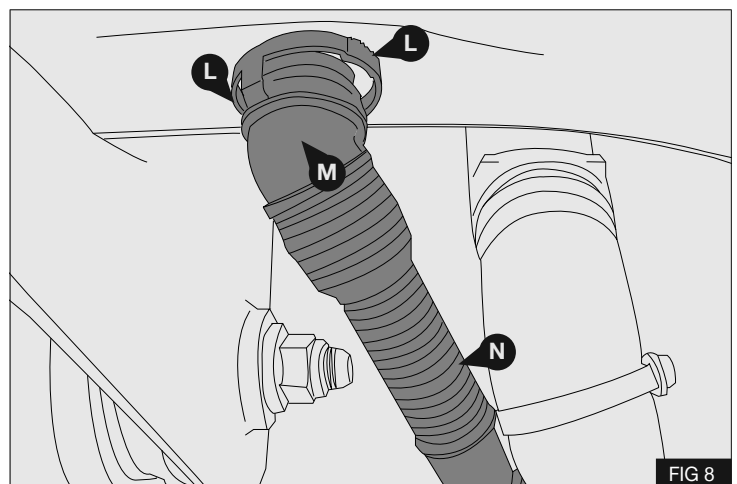

15. Place the supplied hose extension (8) onto the hose adapter (10) and secure using hose clip (14). Secure the original hose fitting (M) to the hose extension (8) using hose clip (14) – Fig 9

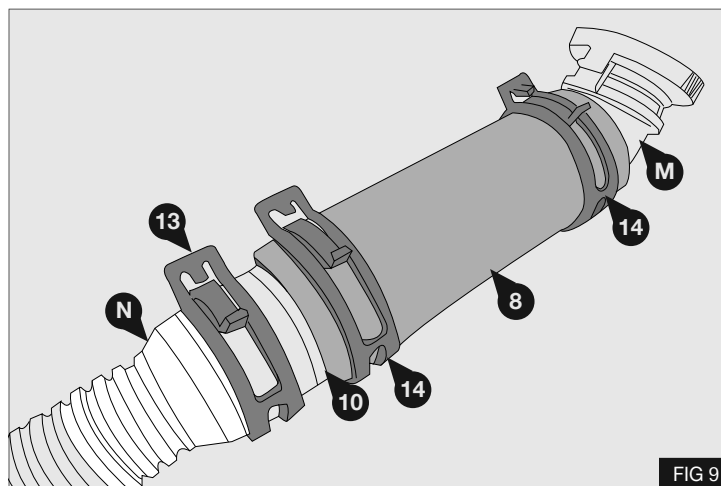

16. Remove the 2x original p-clips (P) from along the length of oil pipe (N) – Fig 10

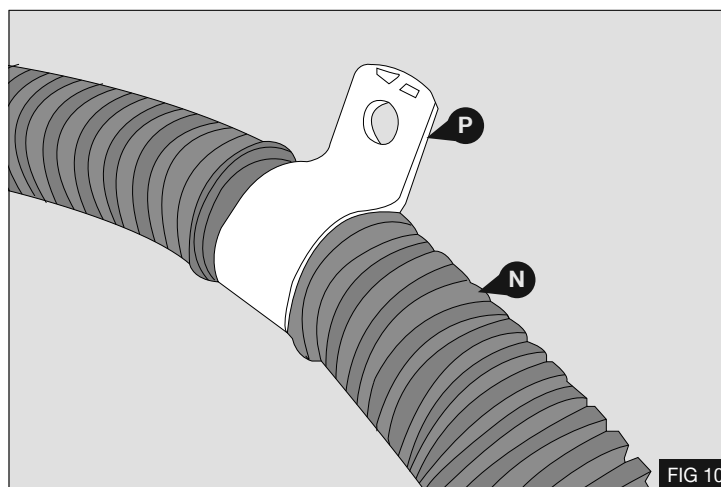

17. Place the length of nylon split tubing (9) around the oil pipe (N). Secure the oil pipe at the position shown through the alternator body with 2x supplied cable ties (11) – Fig 11

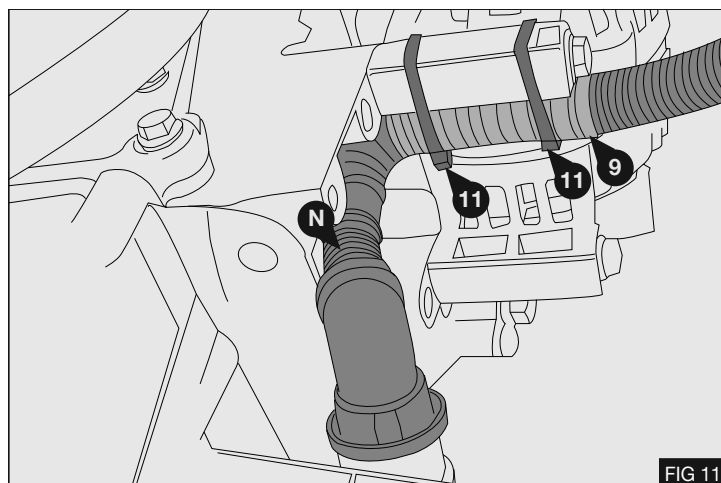

18. Refit the oil fill pipe (N) to the cab and secure the oil pipe to the original fixing on the coolant hose near the cab connection using supplied cable tie (11). Ensure that the ears on hose clips (13) and (14) cannot rub against any original hoses.

19. Attach the oil fill pipe (N) back to the cab and secure to the original fixing locations on the chassis using the supplied p-clips (12) with original bolts as shown opposite – Fig 12

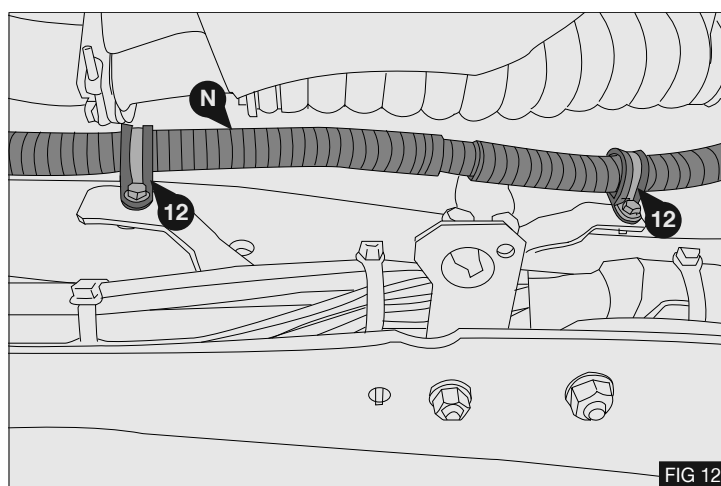

20. Re-connect the fan plug (A) – Fig 13
Remove and discard M8 bolt (Q) from the timing case - Fig 13

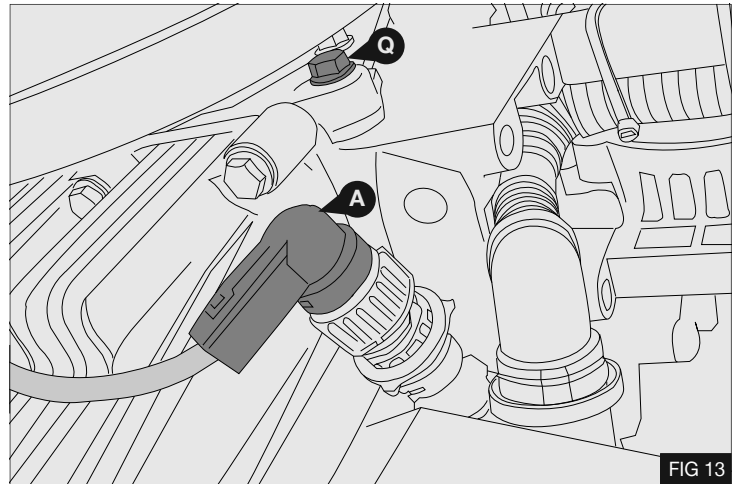

MOUNT BRACKET INSTALLATION

1. Position the automatic tensioner (3) onto the mount bracket (1) as shown opposite and secure with M8x20 bolt (21). Note position of locating dowel (R) – Fig 14

Torque bolt (21) to 29Nm / 21.4lb ft -Fig 14

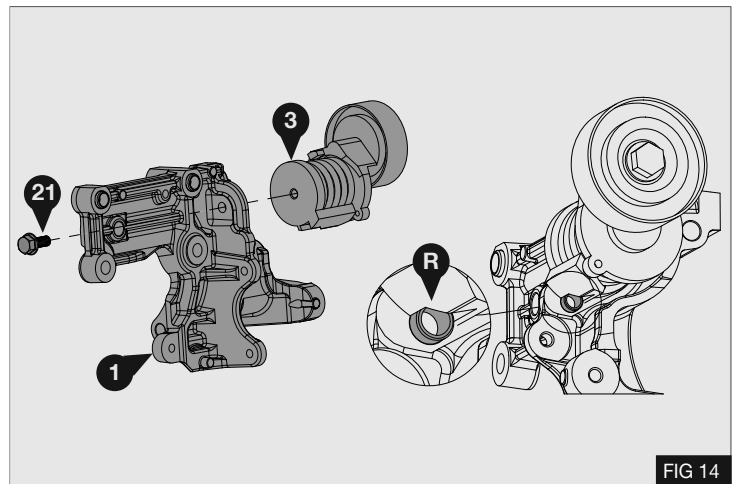

2. Fit the mount bracket (1) to the position below the alternator. Locate the bracket to the dowel holes on the block. Secure using bolts (16), (19) and bolt (17) with washer (23) – Fig 15

Torque bolts (16), (17) and (19) to 58Nm / 42.8lb ft – Fig 15

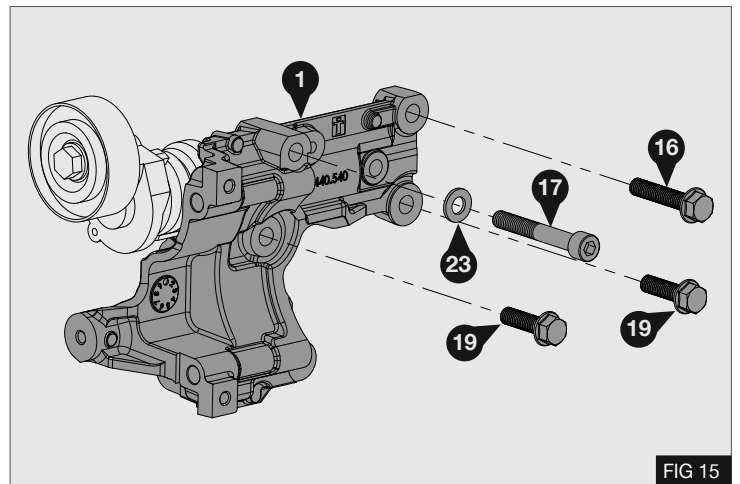

3. Secure the fan loom plug (A) to the rear of support plate (6) using cable tie (11) as shown opposite – Fig 16

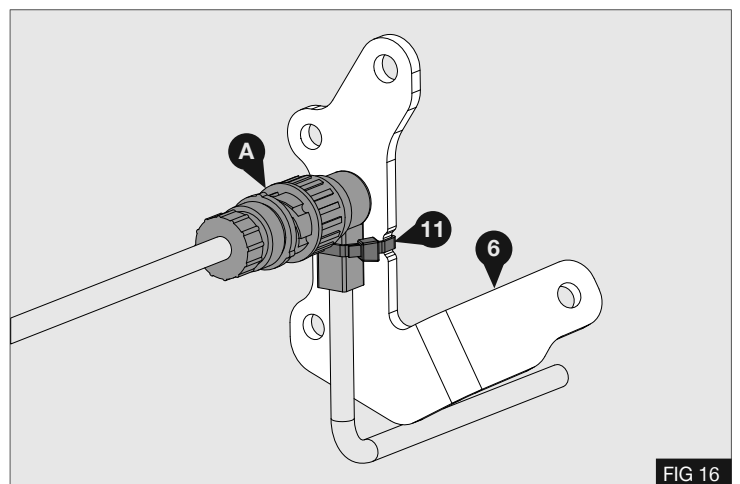

- Secure the support plate (6) to the mount bracket (1) using 2x bolts (21). Insert bolt (20) through the support plate (6) into the timing case - Fig 17

Torque bolts (20) and (21) to 29Nm / 21.4lb ft. – Fig 17

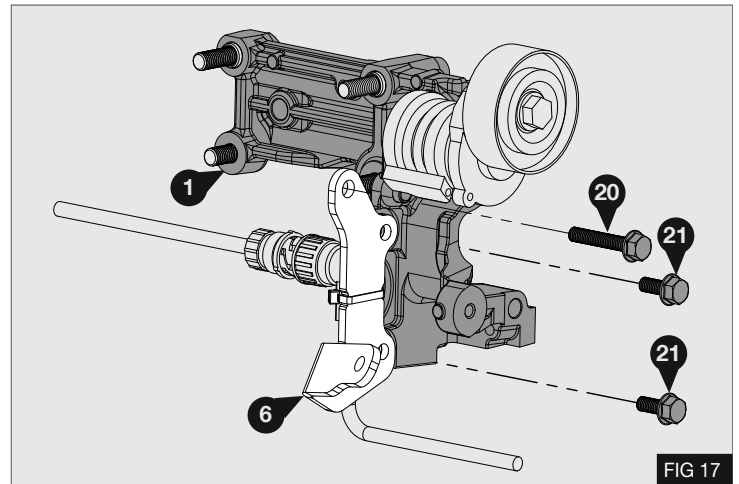

- Refit the original P-clip (B) of the fan loom to support plate (6) using the original fastener into supplied nut (24) – Fig 18

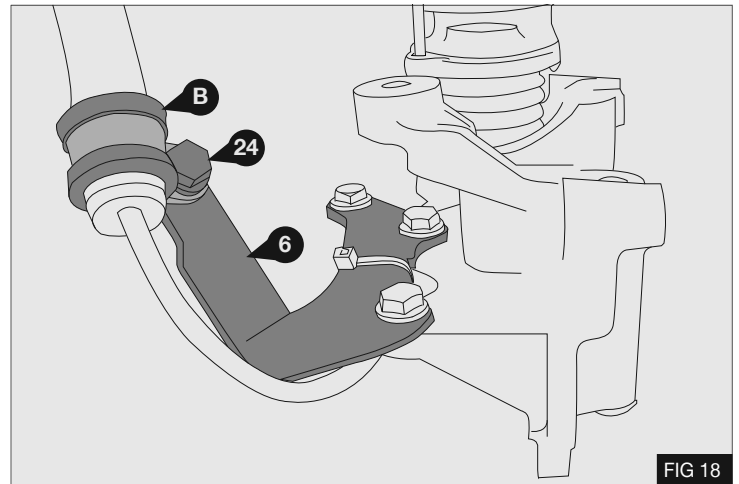

COMPRESSOR INSTALLATION

- Install the supplied manifold (7) to the compressor in the inverted orientation as shown opposite – Fig 19

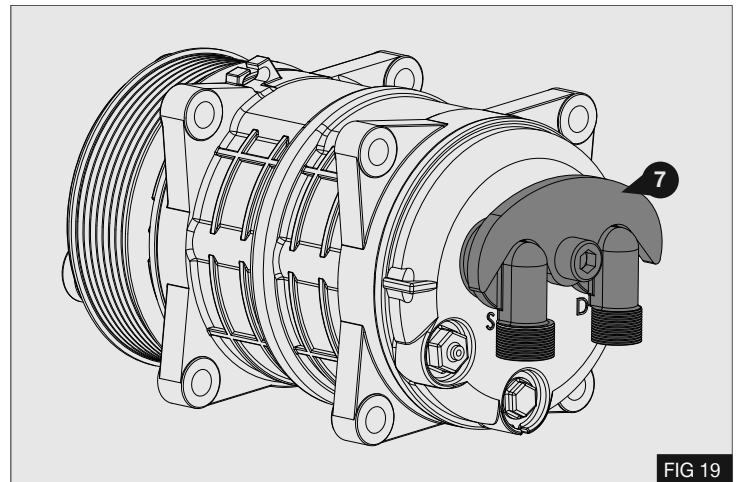

- Install the compressor to the mount bracket (1) as shown opposite using bolts (15) with washers (23) and nuts (22) – Fig 20

Torque bolts (15) to 58Nm / 42.8lb ft. – Fig 20

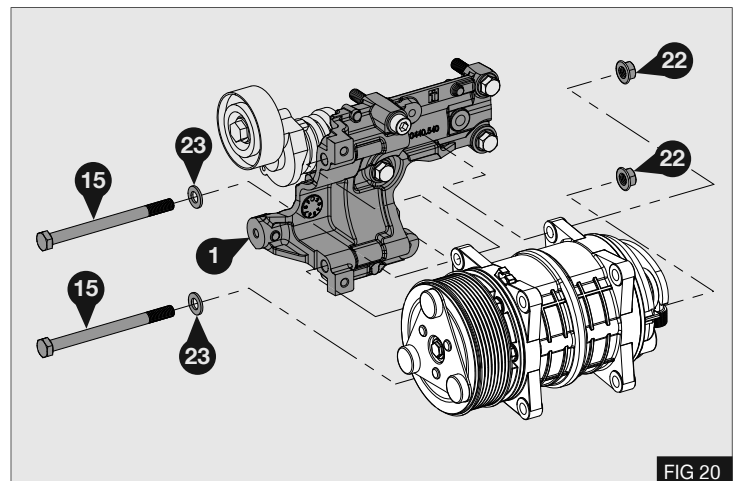

3. Install the idle pulley (4) to the mount bracket (1) – Fig 21

Torque the idle pulley retaining bolt to 25Nm / 18.4lb ft. – Fig 21

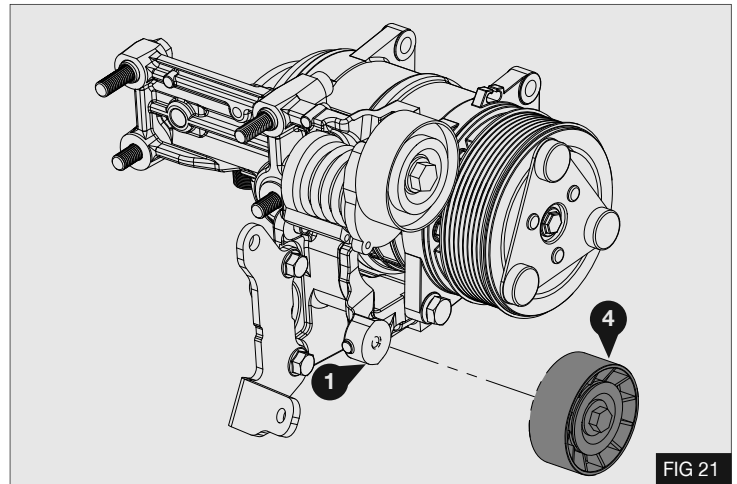

DRIVE BELT

1. Install the supplied drive belt (5) as shown opposite – Fig 22

A – Crankshaft Pulley
 B – Tensioner Pulley
 C – Compressor
 D – Idle Pulley

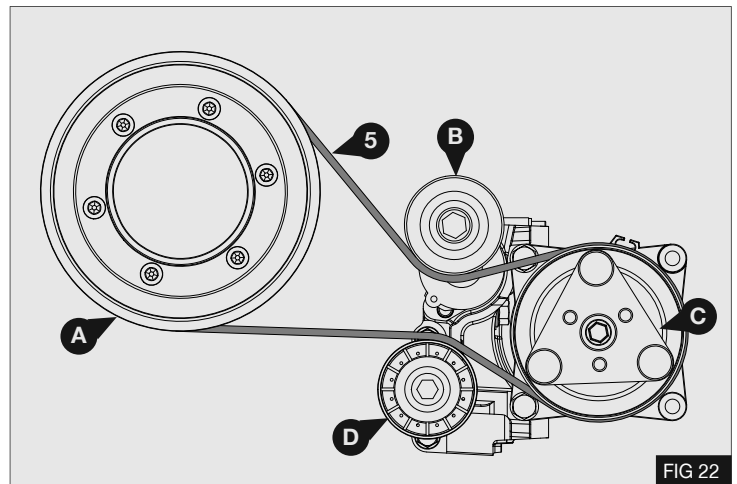

2. Place the belt in the correct groove of the compressor clutch as shown opposite (Seltec / Que PV8) – Fig 23
3. Remove locking pin from tensioner (3)

CAUTION: Once the belt has been installed check for adequate clearance to the fan loom. If required adjust the P-clip securing the fan loom to gain maximum clearance.

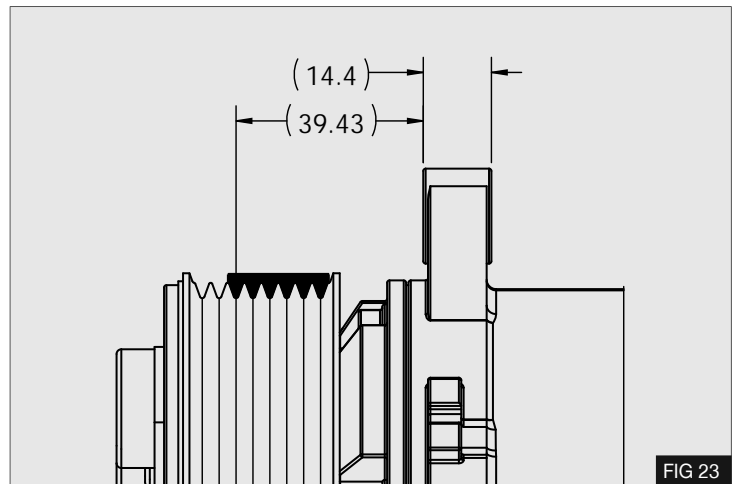

4. Install the pipe work to the compressor – Fig 24
5. Cut the under panel as required to clear the pipe work from the compressor. An example (S) of the cut required is shown opposite.

FINISH

6. Run the engine with the compressor clutch engaged for five minutes. Check all components.
7. Install the supplied belt label in the engine bay.

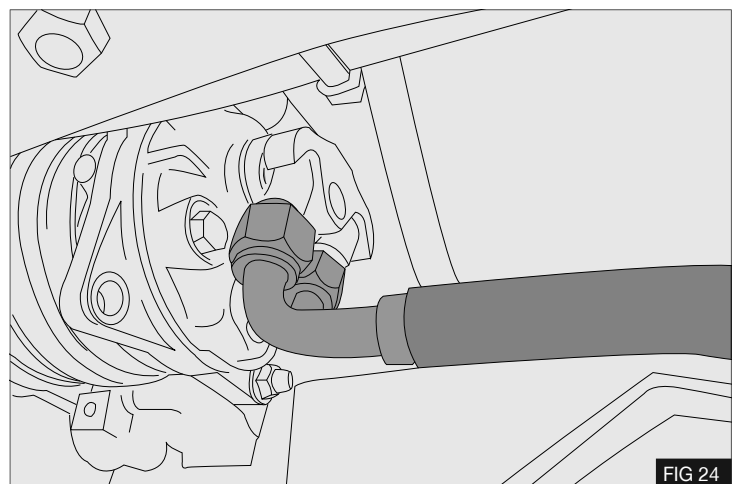

(EN)

Techni focuses on constant upgrading of its products. The Manufacturer reserves the right to modify the models and components described in the present publication at any time for technical or commercial reasons and without prior notice. For further information, contact Techni technical services.

(DE)

Techni ist stets bestrebt die eigenen Produkte zu verbessern. Die Herstellerfirma behält sich das Recht vor, aus technischen oder Verkaufsgründen, zu jeder Zeit und ohne vorherige Ankündigung, Abänderungen an den Modellen und den in dieser Veröffentlichung beschriebenen Einbauteile vorzunehmen. Für weitere Informationen bitten wir Sie, sich an unseren Techni Kundendienst zu wenden.

(FR)

Techni vise à une amélioration constante des ces produits. La maison se réserve le droit d'apporter, à tout moment et sans préavis, des modifications aux modèles et aux composants décrits dans cette publication pour des raisons d'ordre technique ou commerciale. Pour d'ultérieures informations s'adresser au service d'assistance Techni.

(IT)

Techni mira ad un costante miglioramento dei propri prodotti. La Casa si riserva il diritto di apportare in qualunque momento e senza preavviso modifiche ai modelli e ai componenti descritti in questa pubblicazione per ragioni di natura tecnica o commerciale. Per ulteriori informazioni rivolgersi al servizio assistenza Techni.

(ES)

Techni aspira a un constante mejoramiento de su producción. La Fábrica se reserva el derecho de aportar en cualquier momento y sin preaviso modificaciones a los modelos y los componentes descritos en esta publicación por razones técnicas o comerciales. Para ulteriores informaciones dirigirse al servicio asistencia Techni.

VENDITA E SERVIZIO
VENTE ET SERVICE

SALES AND SERVICE
VERKAUF UND SERVICE



Sundorne Trade Park, Henley Way,
Shrewsbury, United Kingdom, SY1 4NS
Telephone (+44) (0) 1743 443176
Fax (+44) (0) 1743 443113
Email: sales@techni.co.uk